

# AASHTO TIG

## Promoting the use of Precast Concrete Pavement Systems



Highways for Life  
PCPS Showcase  
NJDOT, Mt. Arlington NJ  
Timothy J. LaCoss

# AASHTO TIG Lead States Team



# Our Mission



To promote the use of Precast Concrete Pavement Systems for the Repair, Rehabilitation and Reconstruction of PCC Pavements to transportation agencies and owners nationwide.

# PCPS Basics

- Fabricated off-site
- Transported to the project site
- Installed on a prepared sub-base foundation
- No field curing or time to achieve strength
- Two main classifications of PCPS
  - Jointed Systems
  - Prestressed Systems

# PCPS General Terminology

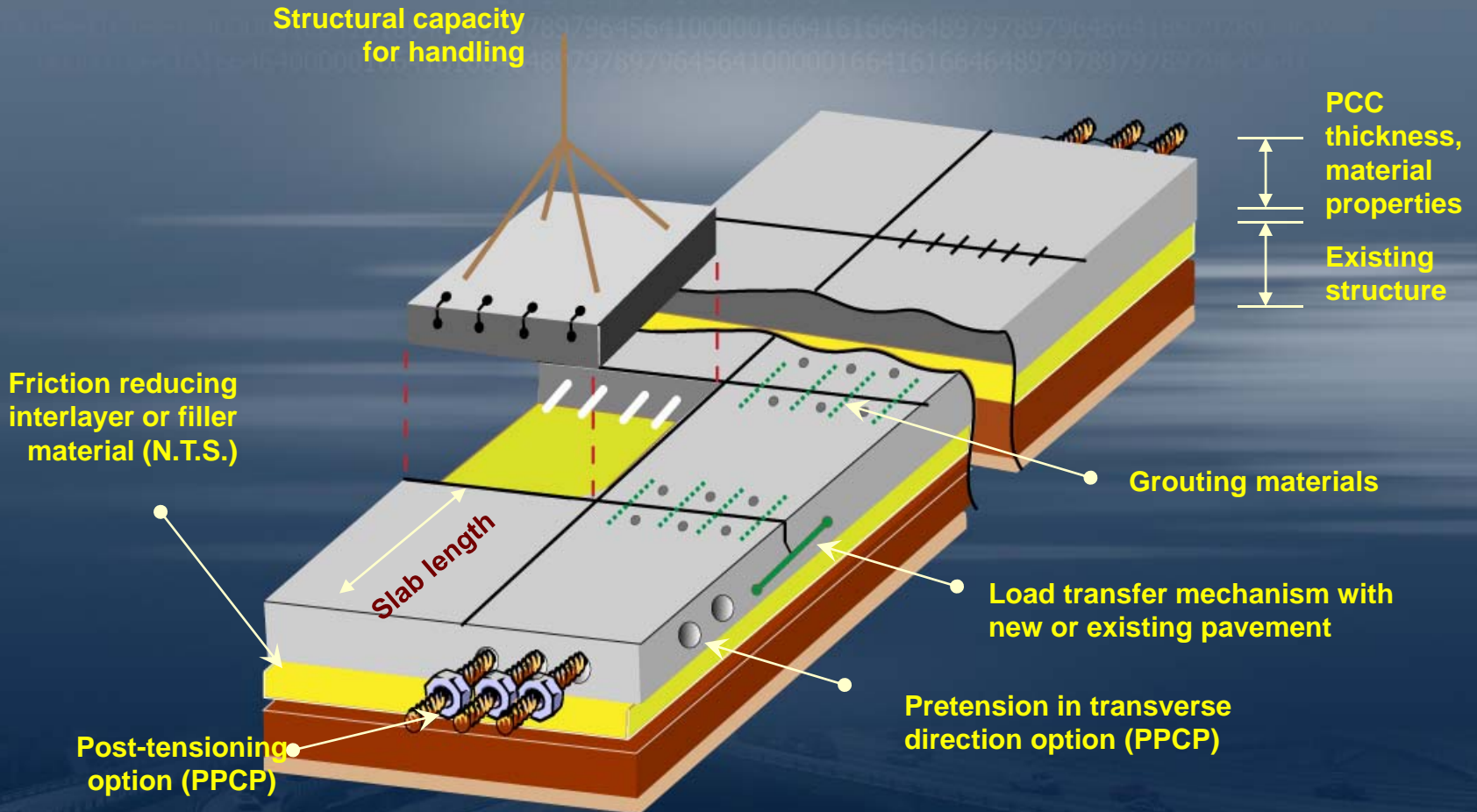

# Paving and Pavement Rehabilitation Applications

- Continuous Paving
- Intermittent Full Depth Repairs of PCC Pavements
- Applications: airport runways & taxiways, heavily traveled highways, ramps, toll plazas, intersections, crosswalks, ports-docks, bus pads, smart-sensor embedment's, bridge approach slabs, pavement under bridges – vertical clearance

# Benefits of PCPS

- Cast under ideal conditions
- Long life expectancy with low maintenance
- Placement in a short time frame – congestion & safety
- Less Risk to owner/contractor
- Growing documentation of performance history
- Established industry, method and technology
- Staged construction is possible
- Installation not affected by adverse weather conditions
- Supported by FHWA, AASHTO, ACPA, NPCA, PCI
- Reduced Work Zone timeframe
- Choice of surface Textures
- Pre-approval of PCPS System is possible
- Pre-existing specifications are available
- Generic specifications are available
- Economically competitive with alternative PCC pavement treatments

# Snapshot of Precast Concrete Pavement Systems in the USA (2006)

## ■ **Precast Prestressed Concrete Pavement System**

- **Precast/Prestressed Concrete Paving System** (non-proprietary)
  - Pre-stressed/Post-tensioned Panel system
  - FHWA Sponsored (CPTP program)

## ■ **Conventionally Jointed Precast Concrete Pavement Systems**

- **Uretek USA System** (proprietary)
  - Precast Panels on HDP foam with 'Stitch in Time' load transfer device
- **Kwik Slab System** (proprietary)
  - Slab on grade, full load transfer, grout bed
- **Ft. Miller – Super-slab System** (proprietary)
  - Slab on grade with full load transfer, grout bed
- **Michigan - Precast Full Depth Replacement/DBR** (non-proprietary)
  - Slab on flowable fill or HDP – dowels on top



# Uretek USA Method

Uretek USA, Inc.

P.O. Box 1929

Tomball, TX 77377-1929

[www.uretekusa.com](http://www.uretekusa.com)

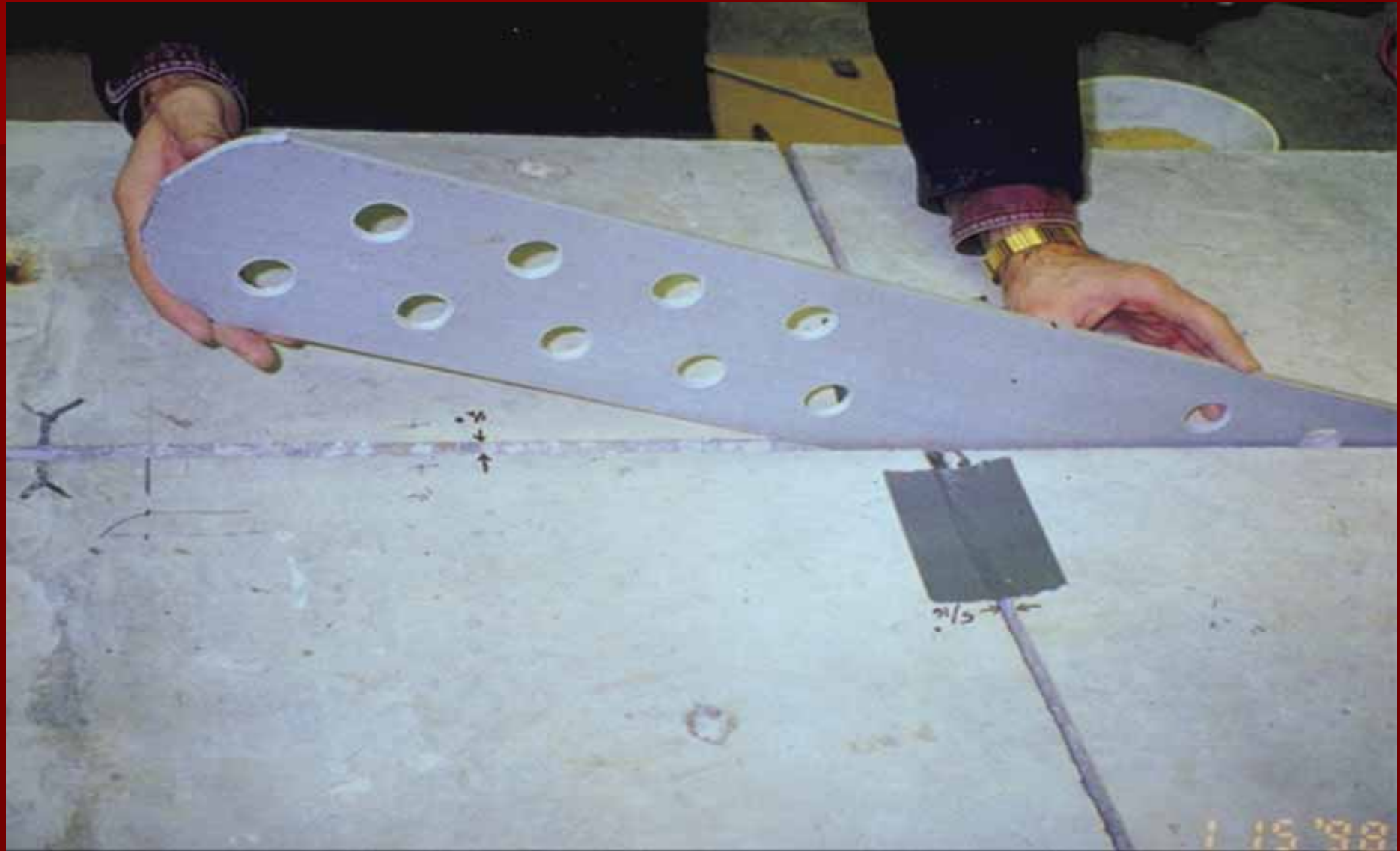



# Kwik Slab, LLC

Kwik Slab, LLC  
1217 Palolo Avenue  
Honolulu, HI 96816  
(808)733-8682

[www.kwikslab.com](http://www.kwikslab.com)

# KWIK SLAB AND KWIK JOINT COUPLER

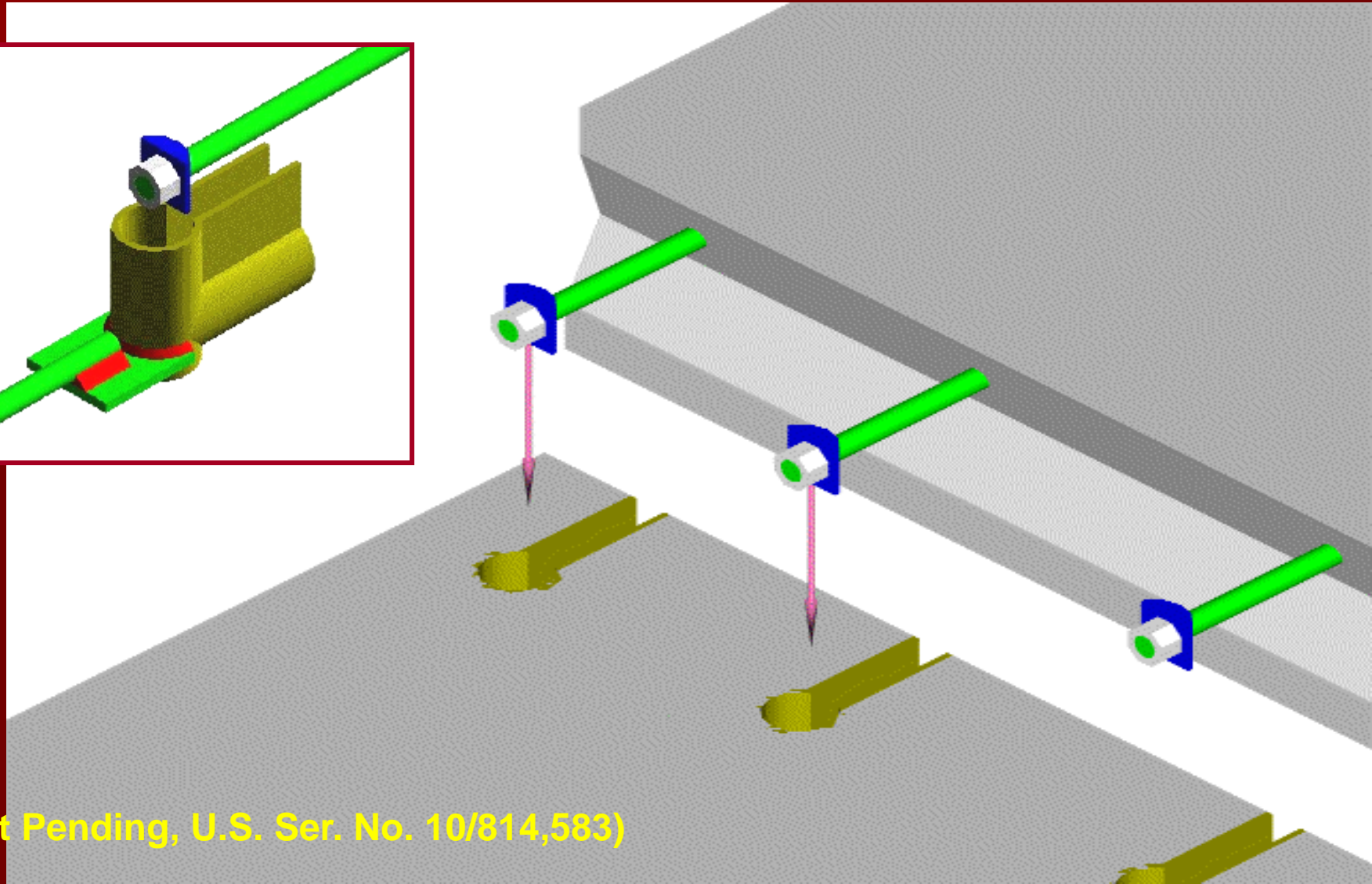
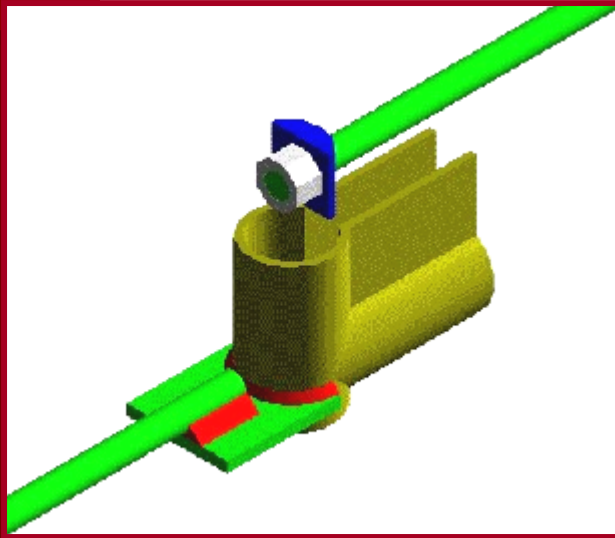

(Patent Pending, U.S. Ser. No. 10/814,583)



KWIK JOINT couplers  
are cast into the  
KWIK SLABS at the  
precast yard.

# Ft. Miller Super-Slab

Ft. Miller Company

P.O. Box 98

Schuylerville, New York 12871

(518)696-5000

[www.fortmiller.com](http://www.fortmiller.com)





# Two Types of Slabs (and Subgrade Surface Profiles)

- Single Plane



- Warped Plane

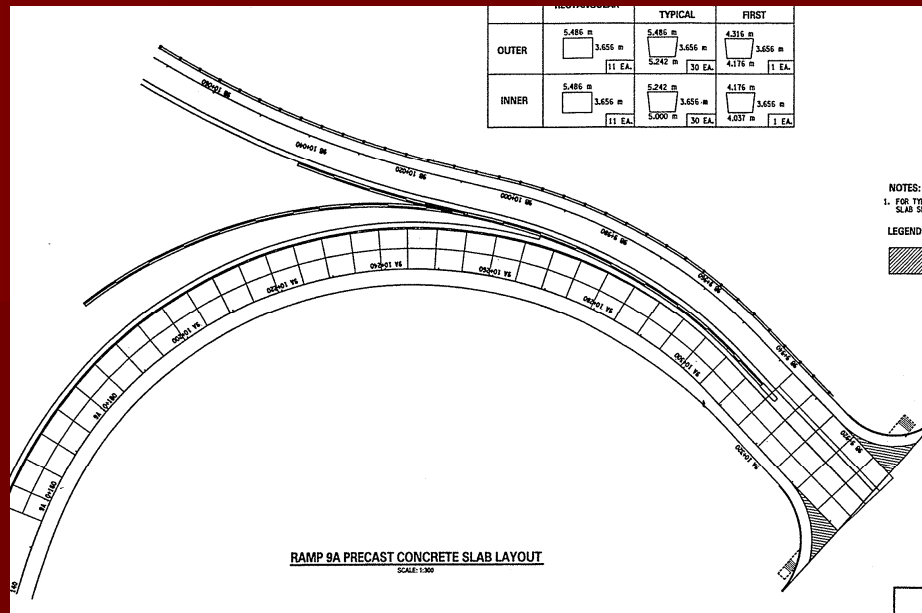

### 3 – D Supergrading (Above)

## 9A Ramp Tarrytown, NY

- All slabs warped
- All slabs trapezoidal (pie shaped)
- Traffic continuously maintained



# Precast Prestressed Concrete Pavement

FHWA-HIPT

Sam Tyson

(202)366-1326

[www.precastpavement.com](http://www.precastpavement.com)

# Panel Assembly

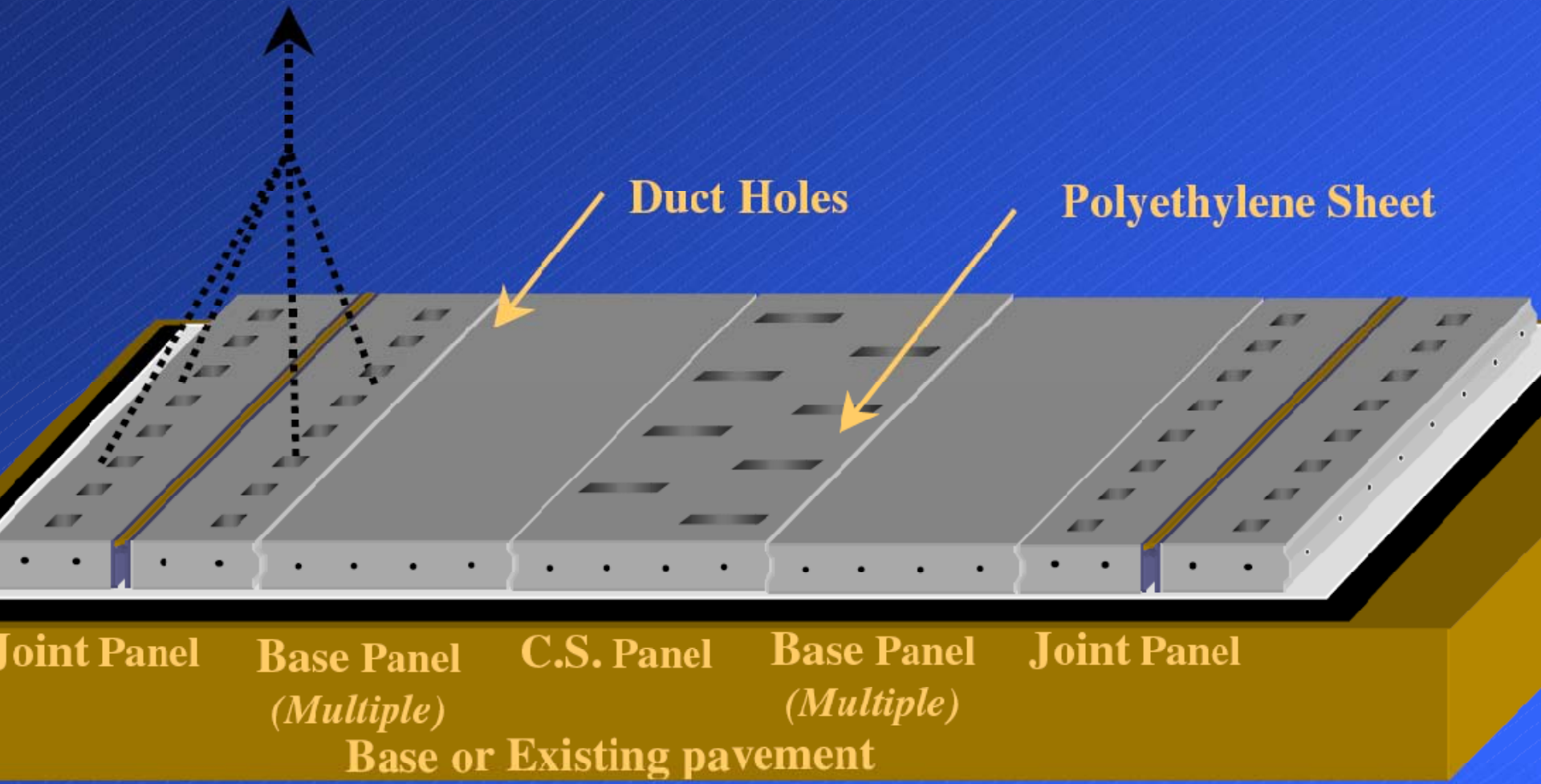

Traffic Flow



# Precast Full Depth Replacement / Dowel Bar Retrofit Method

# Full Depth Repair/Dowel Bar Retrofit





# AASHTO TIG SPECIFICATIONS & GUIDELINES FOR PCPS

1. Guidance and Considerations for the Design of Precast Concrete Pavement Systems

2. Generic Specification for Fabricating and Constructing Precast Concrete Pavement Systems

3. Generic Specification for Precast Concrete Pavement System Approval

4. Precast Concrete Pavement Systems for Rapid Pavement Repair and Replacement: Basic Information and Commentary

Available at [WWW.AASHTOTIG.ORG](http://WWW.AASHTOTIG.ORG) under the PCPS dropdown menu



[www.aashtotig.org](http://www.aashtotig.org)

## What's available on-line?

- Detailed information about each of these 5 leading Precast Paving Systems.
- Design Guideline Specifications
- Construction Guideline Specifications
- Approval Guidelines for PCPS
- Research Reports
- Proven Agency Specifications

# Joint Work Effort AASHTO & FHWA

## Highways for **LIFE**

**L**ong lasting

**I**nnovative

**F**ast construction

**E**fficient and safe



# PCPS Projects in 2007, 2008 & 2009

- NYSTA I-95 (CT-State line/Mamaroneck River to Cross Bronx Expressway)
- NYSTA I-190 (Buffalo)
- NYSDOT – Nassau-Queens Expressway, Staten Island-West shore Expressway
- NJDOT I-280 & Rt.21 (Trenton) ★
- Toronto, Canada (Downtown, Hwy 427)
- Illinois State Toll Authority (I-290/I-294 & I-88 & I-355)
- Iowa DOT (precast bridge approaches)
- DELDOT, intersection Rt.896 & Rt. 40 (Bear, DE) ★
- Highways for Life Projects
  - Virginia DOT I-66 Interchange Ramp ★
  - Florida DOT (Daytona) - Intersections
  - CALTRANS I-15 - Mainline ★
  - NYSDOT I-88 Bridge Approach Slabs (Central NY)



HfL/AASHTO TIG Sponsored Product Showcase

Coming Soon !!!

# Conclusions

- The technical framework, treatment philosophy, and PCPS systems are in place
  - For continuous and intermittent repairs
  - For all types of dimensional road geometries
- It is a proven pavement treatment alternative that fits well into Accelerated Construction Practices
- Aggressive Educational Outreach effort underway by FHWA /AASHTO-TIG on PCPS, creating market demand.
- The Momentum is growing...FAST!!!

# Thank you !

Timothy J. LaCoss  
Pavement & Materials Engineer  
FHWA-NY Division  
(518)431-4125, ext.260  
Timothy.LaCoss@fhwa.dot.gov

To find out more details about  
Precast Pavements look at  
[WWW.AASHTOTIG.ORG](http://WWW.AASHTOTIG.ORG)