

SELECTION, INSTALLATION AND USAGE OF HATCHES

TECH NOTE



NPCA

Precast... The Concrete Solution

Hatches for utility structures are manufactured from cast iron, aluminum and steel. The casting requirements, in regard to concrete cover and required steel reinforcing, differ depending on material type. These requirements also vary based on expected load and required hatch size. Using the right accessories, casting the hatches and using the hatches according to manufacturer's recommendations, or specifications such as ASTM C1802, will protect the structures lifespan.



FABRICATED HATCHES

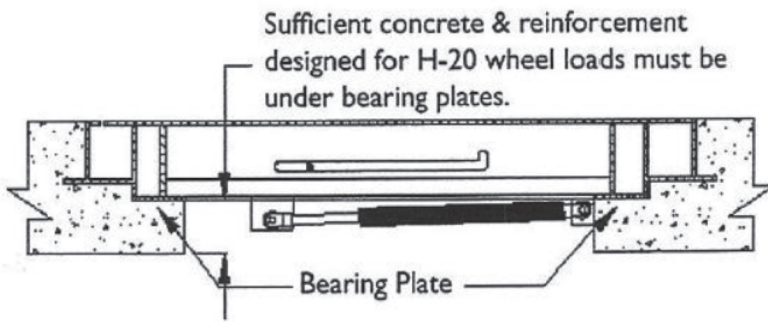

Products utilizing steel or aluminum are typically referred to as fabricated doors. These doors transfer the applied load through beams to bearing plates on each end. Unlike cast iron, these bearing plates are not designed to adequately support the design loads. This area may require additional reinforcement and concrete support to transfer the design load.

Typical Traffic Bearing Hatch Cast into Corner of Top Slab

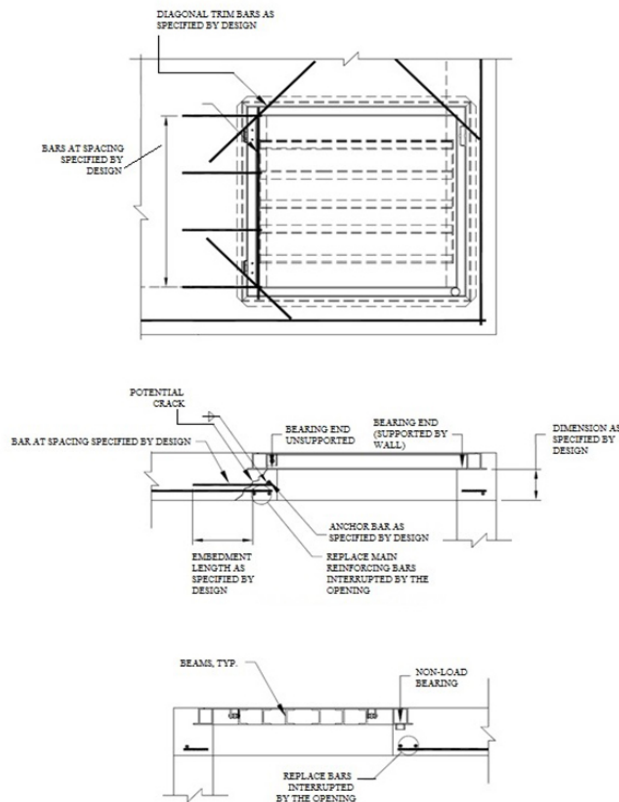

The use of an attached, fabricated skirt is strongly recommended to ensure the bearing plate is supported by the precast concrete structure. All fabricated hatches intended for loads heavier than pedestrian traffic should use a fabricated skirt. If using an aluminum product, a bituminous coating shall be applied to the areas of the skirt and frame in contact with concrete. The alkalis in concrete are corrosive to aluminum and will deteriorate an aluminum door over time.



Shear reinforcement, if necessary under the bearing surface, and properly consolidated concrete is required under bearing end plates. Structural cracks in the concrete at these end supports will reduce the potential for the specified door to meet the design loads.

Professional guidance and design is recommended for all structures using hatches. Engineered and stamped designs shall be required for all traffic rated and airport designs. The required design varies with the clear opening of the hatch size, structure size and intended loading. This results in varying top slab thicknesses as well as required reinforcing. Place any required drains on the side of the hatch, away from the ends of the load bearing beams. If possible, it is efficient to place the load bearing beams directly over the wall of the structure.



Order the fabricated hatch with skirt corresponding to the required slab thickness. Provide a production drawing that locates the hatch according to the clear opening or outside of the attached skirt. Ensure adequate concrete coverage around the reinforcing by placing the reinforcing clear of the frame and other components. It is also important to have the hatch doors securely bolted to the frame when closed. Otherwise, the applied load will create impact and vibration in the frame, damaging the precast concrete top slab and hatch.

Successful production of precast utility structures is based on understanding the product specified, identifying the key components, ordering the required accessories and casting them into the structure properly. Then, use the hatches according to manufacturer recommendations.



CAST IRON HATCHES

Cast iron hatches are available in both “flange down”, which is set on top of a concrete slab, and “flange up”, which is cast flush with the top of the slab.

Cast Iron hatches designed with a flange up, or top flange, frame are intended to be “wet set” in concrete. The top flange design generally eliminates the need for any additional anchoring typically used with “flange down” applications.

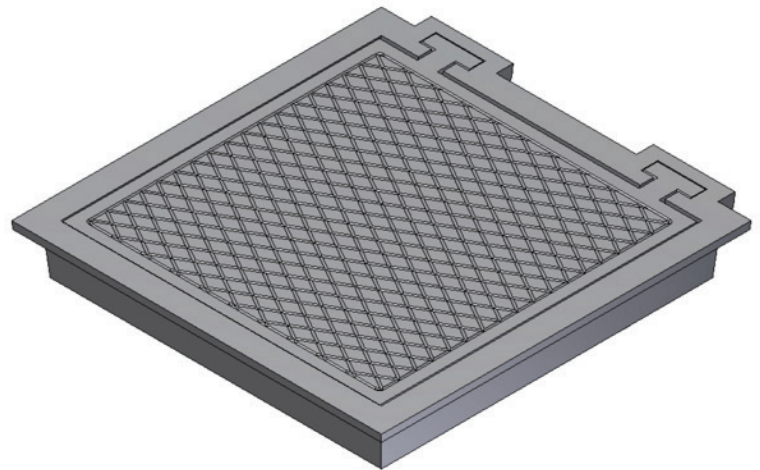

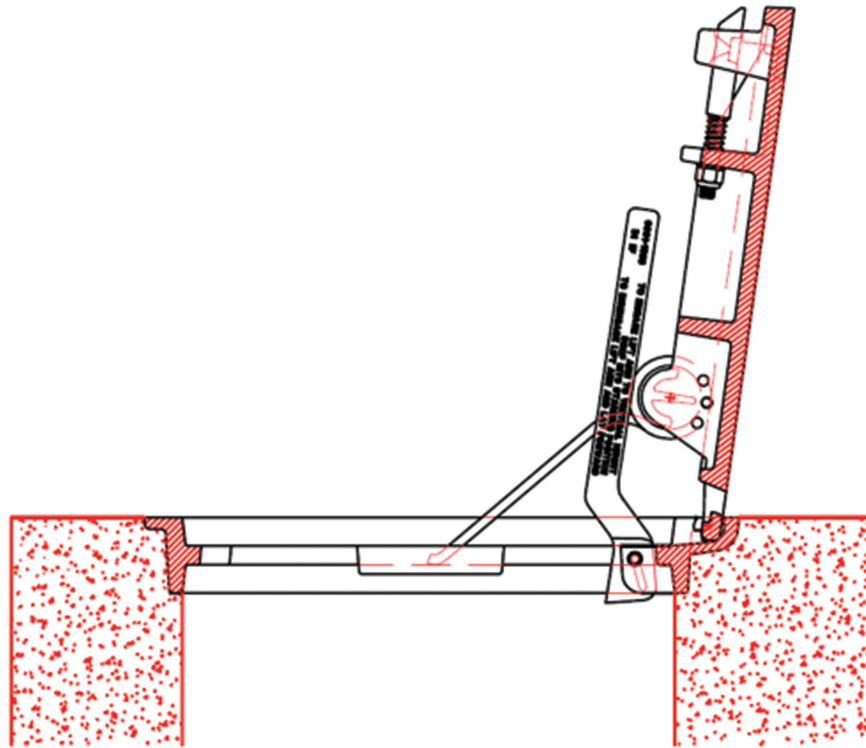

Cast Iron hatches are available for a variety of loading requirements, ranging from light duty for pedestrian traffic, to extra heavy duty for airfields and ports. Selecting a proper casting requires the services of a qualified professional who knows how and where the hatch will be used, and has the training and experience necessary to take into consideration all the circumstances of the intended application. That includes determining the required strength, capacity and function as well as assessing the casting's suitability for the location in which it will be installed.

Gray iron and ductile iron are commonly used in cast iron hatches. Both are available in a variety of classes or grades to suit the application. The frame of most hatches is cast in gray iron while the cover can be gray iron or ductile iron. Typical specifications for gray iron would be Class 30B, Class 35B and Class 40A. Ductile iron is also available in several grades, with Grade 65-45-12 being the most common in the industry.

This publication is designed to provide accurate and authoritative information, however the National Precast Concrete Association does not guarantee the validity or accuracy of any data, claim or opinion appearing in this publication. If engineering, legal or other professional services are required, the services of a competent professional should be obtained. The National Precast Concrete Association does not assume and hereby disclaims liability to any person for any loss or damage caused by errors or omissions in this publication, regardless of whether such errors result from negligence, accident or any other cause whatsoever.