



NPCCA

National Precast Concrete Association

precast.org

PRECAST
CONCRETE BOX
CULVERTS

OUTLINE

- **Introduction**
- **Applications**
- **Manufacturing Methods**
- **Design Procedures & Joints**
- **Installation**
- **Quality**
- **Summary**



INTRODUCTION

Four-sided culverts are typically referred to as box culverts.



INTRODUCTION

- **Standard box sizes: 3' x 2' to 12' x 12' in 1' span and rise increments.**
- **Typically come in 6' and 8' lengths.**
- **Custom box sizes:** Nonstandard sizing is permissible and must be designed per project design specification.

INTRODUCTION

- **Three-sided structures** are U-shaped structures that may or may not have a crown in the center.



INTRODUCTION

- **Standard three-sided structures range from 8' to 48' span lengths.**
- **Custom sizes are available and must be designed per project design specifications.**

APPLICATIONS

Box culverts

- Short-span bridges (over highways, waterways, railways, for golf courses, etc.)
- Conveyance of stormwater, sewage or industrial wastes (storm drains)
- Tunnels (to house conveyers, utilities, etc; to provide access, escape routes, etc.)
- Detention

Three-sided culverts

- Short-span bridges (flat and arched)

APPLICATIONS

Benefits:

- Box culverts can be made in large sizes to accommodate increased flow rates and capacities.
- Boxes can be set with 0 feet to 100 feet of cover.

STORMWATER CONVEYANCE



Typical small
stream crossing.

TUNNELS



Fast and economical method for tunnels under roadways, as in this golf cart tunnel.

TUNNEL & ESCAPE ROUTES



Provide for emergency egress, as with this tunnel underneath a warehouse and distribution center.

STORMWATER DETENTION



Multicell box culvert installation to economically provide storage of storm water runoff.

CUSTOM BOX SIZES



Custom designed and manufactured box culverts are available, as with this monolithic triple cell structure.

BENDS CAN BE DESIGNED



MITERS & SIDE OPENINGS



THREE-SIDED STRUCTURES

- Placed on strip footing and used for short span bridges.
- They allow for natural stream beds to remain intact and can meet EPA requirements.



THREE-SIDED STRUCTURES



Large 3-sided structure w/precast headwalls and wing walls.

SHORT-SPAN BRIDGES



Roadway over roadway applications can be accomplished with long-span 3-sided structures.

MANUFACTURING METHODS

Wet-Cast

- Typically cast on end using an inner and outer form.
- Blockouts / hole formers can easily be incorporated.
- Cast with conventional concrete or self-consolidating concrete.
- Product cured in the form.
- Wet-cast is commonly used for sanitary applications.

MANUFACTURING METHODS

Dry-Cast (Machine Made)

- Product cast using mechanized equipment.
- Form vibrators consolidate zero-slump concrete between core and jacket.
- Hole formers may be incorporated, or coring is done as needed.
- The product is immediately stripped and the form is reused.
- Products typically cured in a kiln, or a combination of tarps and moisture curing is used.
- Surface may appear textured due to manufacturing process.

DESIGN

- **Designs are dependent on project specifications and applications.**
- **This includes hydraulic design for fluid conveyance structures.**

DESIGN

Fluid Conveyance

- Hydraulic design and sizing are usually performed using Manning's “n” for open channel flow (typical values for “n” are 0.012 for wet-cast and 0.015 for dry-cast).
- This work is usually performed by the owner's engineer, who then supplies the precaster with the size requirements.

DESIGN

Structural design is performed based on application

- After determining the size required, use applicable standards for the box or three-sided structure design.
- This work is usually performed by the precaster or the precaster's engineer.

DESIGN

List of common design standards:

- ASTM C 1433 – Box culverts, for conveyance of stormwater, industrial wastes and sewage.
- ASTM C 1504 – Three-sided structures, for stormwater conveyance and culverts.
- AASHTO Standard Specification for Highway Bridges for short-span bridges.

DESIGN

List of common design standards:

- ACI 318, for tunnels and special design.
- ACI 350R, for wastewater applications.

DESIGN – NOTES

- **Box culverts are subject to:**
 - Lateral earth loads from soil and hydrostatic loads from ground water.
 - Vertical loads from the cover soil and live loads above.
 - Surcharge loads from nearby impact loads.
 - Seismic loads where applicable.

DESIGN – EXAMPLE

Box culvert design for stormwater conveyance

Project data:

Flow rate, $Q = 1000 \text{ ft}^3/\text{sec}$

Length, $L = 800 \text{ feet}$

Initial slope, $S_o = 0.5\%$

Allowable Head Water, $HW = 15 \text{ feet}$

Manning's, $n = 0.012$

DESIGN – EXAMPLE

- **After calculations, it was determined that a 9' x 7' box culvert will handle the required flow. The box will support HS20 loads: Use ASTM C 1433.**
- **Box to be set at 8' depth, use table 1.**

DESIGN – EXAMPLE

9' x 7' x 9" Circumferential Reinforcement Areas, in²/ft

Depth, ft	As ₁	As ₂	As ₃	As ₄	As ₅	As ₆	As ₇	As ₈	M
0<2	0.25	0.58	0.29	0.22	0.22	0.22	0.22	0.22	
2<3	0.25	0.46	0.32	0.22					59
3-5	0.22	0.28	0.30	0.22					54
10	0.25	0.41	0.43	0.22					49
15	0.34	0.56	0.59	0.22					44
20	0.42	0.72	0.74	0.22					44
25	0.51	0.88	0.90	0.22					44

DESIGN – EXAMPLE

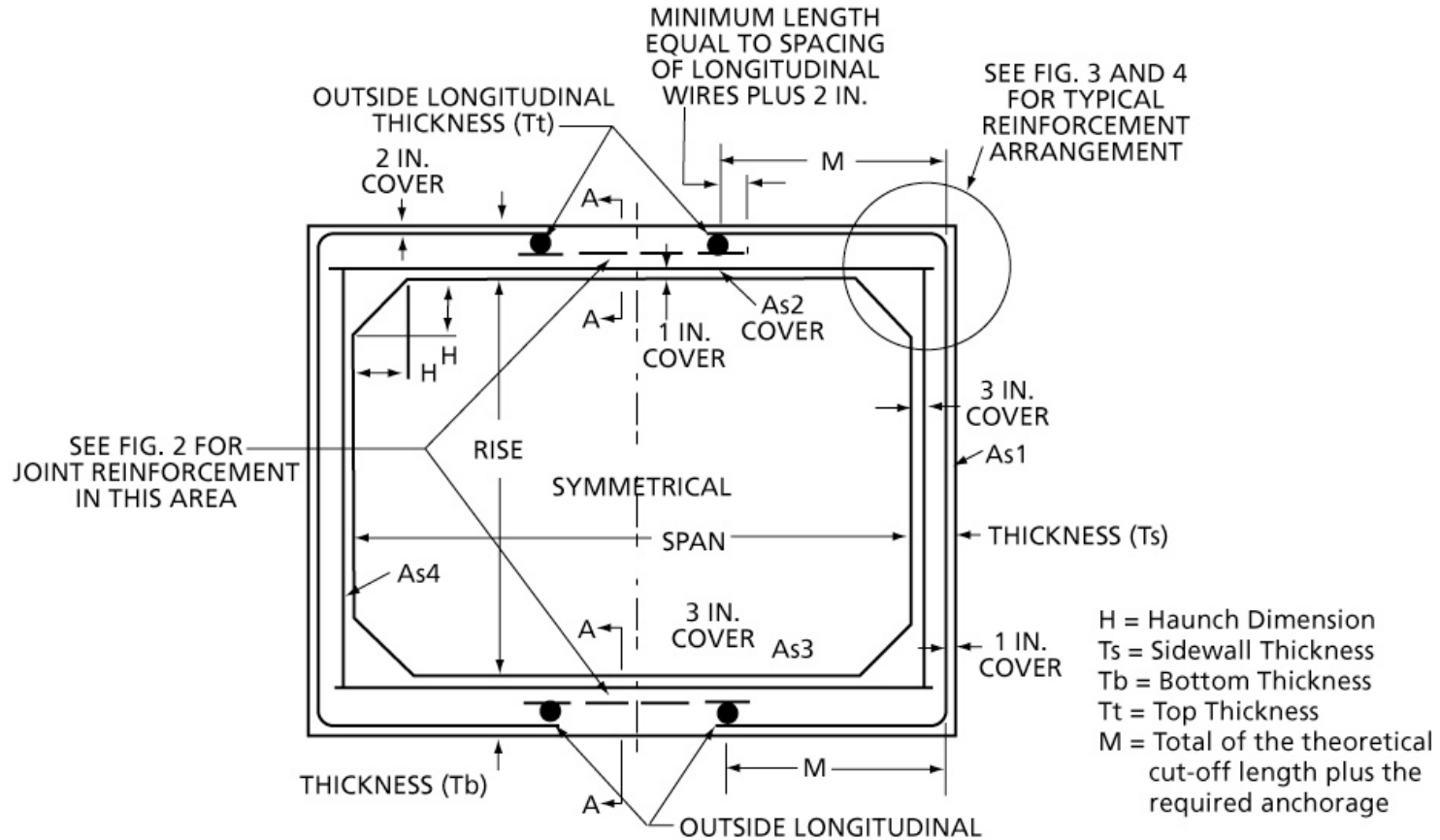

FILL HEIGHT 2 FT AND GREATER

DESIGN – EXAMPLE

Less than 2' Cover - 9' x 7' x 9"

Circumferential Reinforcement Areas, in²/ft

Depth, ft	As ₁	As ₂	As ₃	As ₄	As ₅	As ₆	As ₇	As ₈	M
0<2	0.25	0.58	0.29	0.22	0.22	0.22	0.22	0.22	
2<3	0.25	0.46	0.32	0.22					59
3-5	0.22	0.28	0.30	0.22					54
10	0.25	0.41	0.43	0.22					49
15	0.34	0.56	0.59	0.22					44
20	0.42	0.72	0.74	0.22					44
25	0.51	0.88	0.90	0.22					44

DESIGN – EXAMPLE

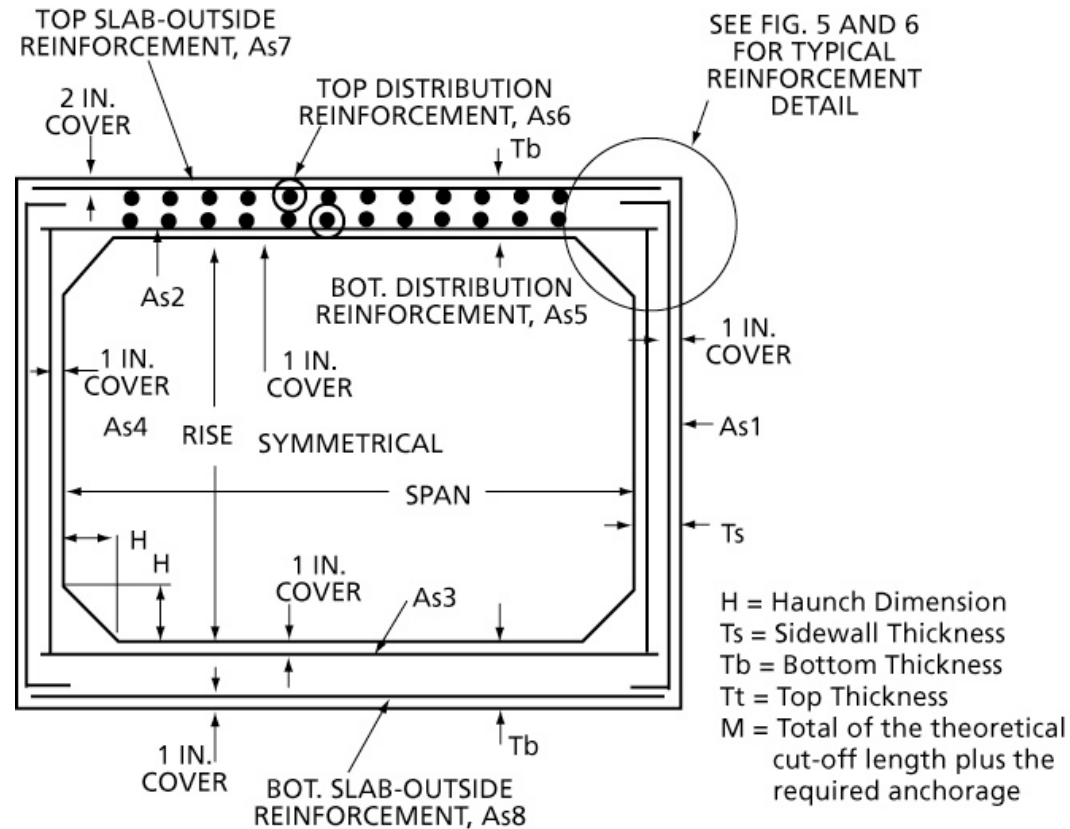

FILL HEIGHT LESS THAN 2 FT

JOINTS – EXTERNAL WRAP

- **ASTM C 877**

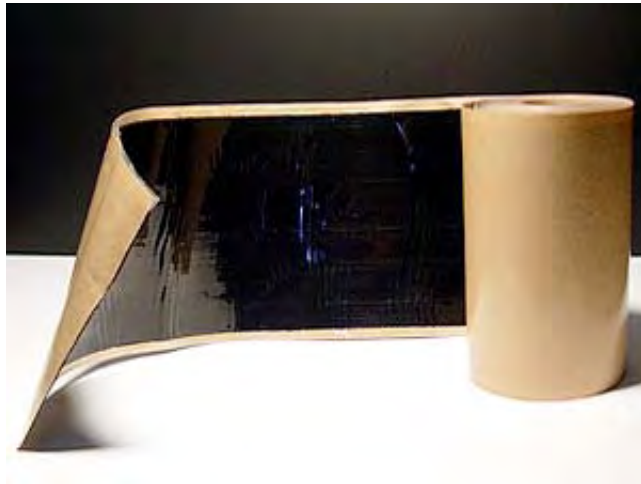

JOINTS – MASTIC/BUTYL

- **ASTM C 990**

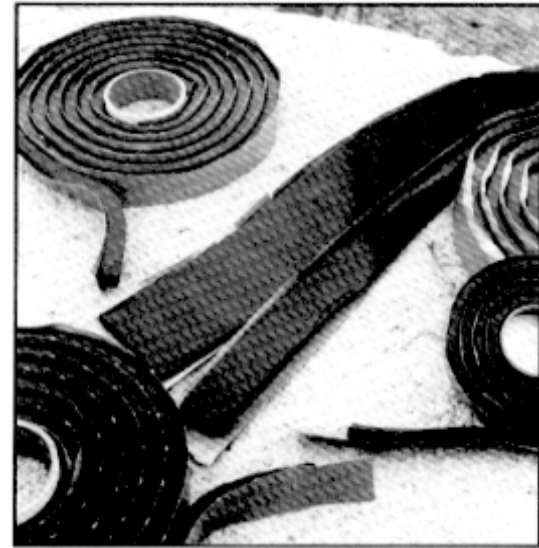

JOINTS

- Closed cellular rubber (vinyl & nitrile elastomers).
- Physical properties of ASTM D1056 Type 2C-1 & chemical resistance requirements of AASHTO M198.
- Requires a joint gap.
- Soil tight only.

JOINTS

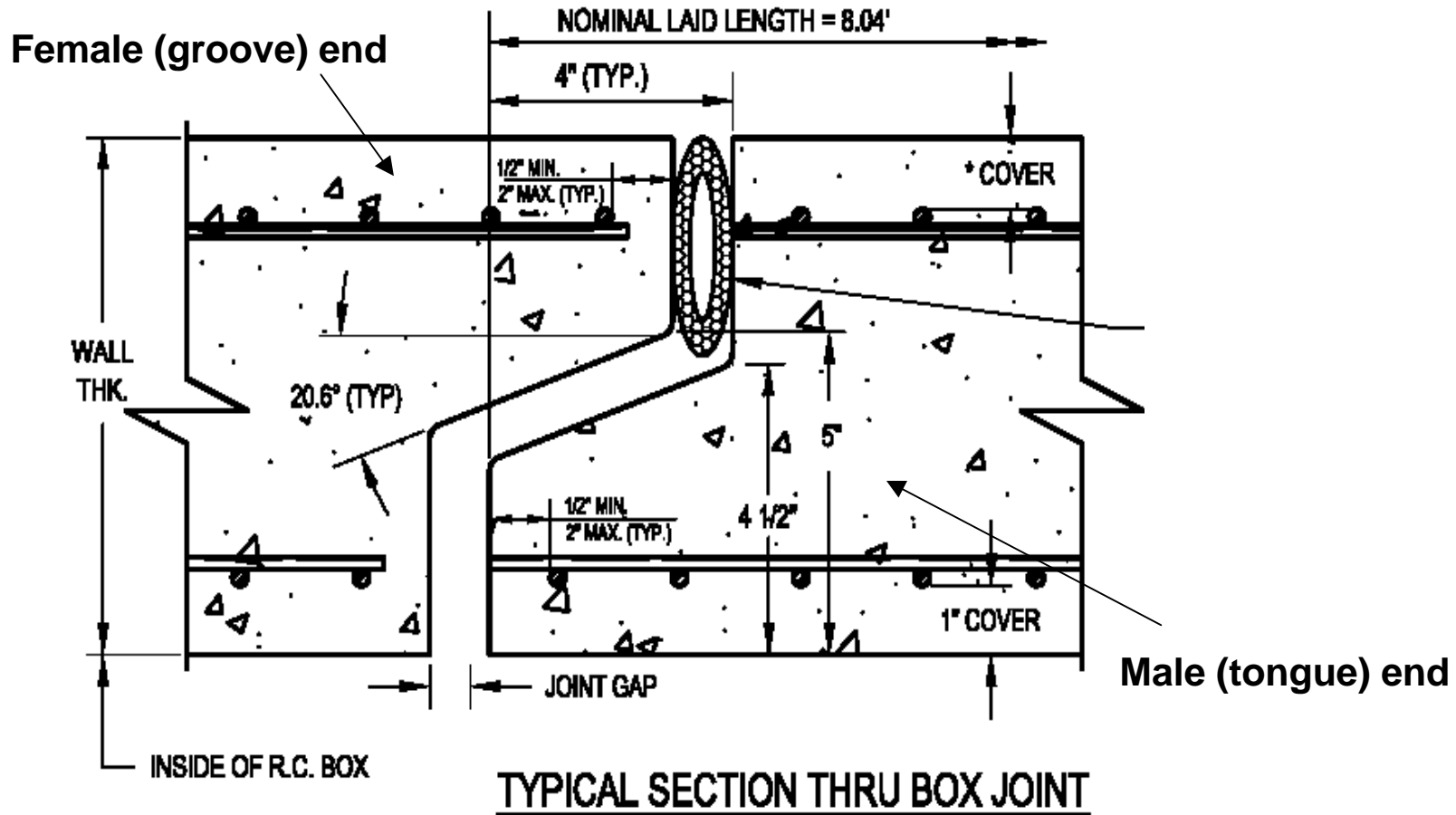

JOINTS

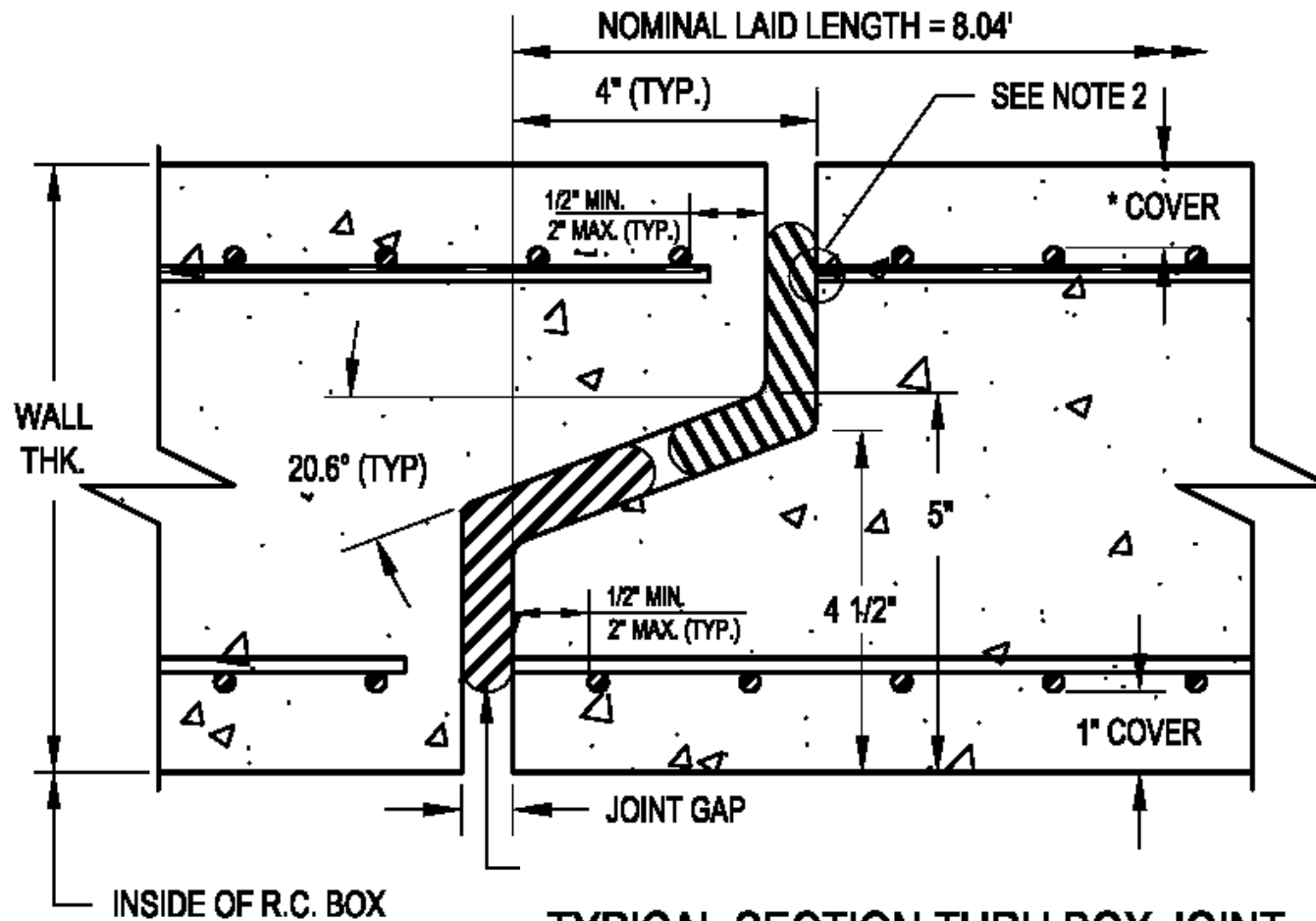

TYPICAL SECTION THRU BOX JOINT

INSTALLATION

- Trench must remain dry during the installation process, dewater if necessary.
- Bedding must be compacted, set to grade and meet specifications.
- Place groove end section first.
- Set subsequent boxes with the tongue end being set into the groove to reduce bedding disruption.

INSTALLATION

- Backfill shall be placed uniformly on each side of the precast concrete box sections. The backfill material to be placed, the percent of compaction, the depth of layers, etc., shall be as required by the contract specifications.

QUALITY

- When purchasing and specifying box or three-sided precast concrete structures, you should specify certified plants.
- NPCA Certification program.

