

A Publication of the National Precast Concrete Association

# PRECAST CONCRETE STORMWATER MANAGEMENT STRUCTURES



# WHY PRECAST CONCRETE?

Why Precast Concrete .....	2
Sustainable Benefits of Precast Concrete .....	3
Installation Procedures .....	4
Certified Excellence .....	5
Industry Standards.....	6
Case Study .....	7
Stormwater Illustrated.....	8-12

## WHY PRECAST CONCRETE?

Precast concrete stormwater management systems have many advantages over competing materials. Here are a few:

### Rough and Tough

The strength of precast concrete gradually increases over time. Other materials can deteriorate, experience creep and stress relaxation, lose strength and/or deflect over time. The load-carrying capacity of precast concrete is derived from its own structural strength qualities and relies very little on the quality of the surrounding soils. Studies have shown that precast concrete products can provide a service life in excess of 100 years. In severe conditions, additional design options are available to extend the life of concrete products.

### We're Talking Quality Here

Because precast concrete products typically are made in a controlled plant environment, they exhibit high quality and uniformity. Problems affecting quality typically found on a job site - temperature, curing conditions, poor craftsmanship and material quality - are nearly eliminated in a plant environment. Precast concrete products manufactured in a quality-controlled environment and installed with high-quality sealants offer a superior solution to watertightness requirements. Standard watertight sealants are specially formulated to adhere to precast concrete, making watertight multiple-seam precast concrete structures possible.

### Installation is Easy

Setting precast concrete structures into place is easier because they do not require special rigging (such as fabric slings) to avoid structural damage. Other materials such as fiberglass can suffer structural damage during compaction. In contrast, precast concrete is less susceptible to vibratory damage while the surrounding soil is backfilled. Consequently, backfilling operations can usually proceed much faster around precast concrete structures.

### Heavyweight Champion

With a specific gravity of 2.40, precast concrete structures resist the buoyant forces associated with underground construction. In comparison, fiberglass has a specific gravity



of 1.86, and high-density polyethylene (HDPE) has a specific gravity of 0.97.

### Ready for Anything

While no material is completely immune to chemical attack, the mix designs used to produce precast concrete can be adjusted to help withstand anticipated corrosive agents. Materials such as steel and other materials quickly deteriorate in the presence of corrosive agents, some in the presence of water alone. To better protect reinforcement from corrosion, the precast concrete strength should be designed to 4,000 psi or more.

### Looks Good in GREEN

Besides water, concrete is the most used material on earth. It is nontoxic and environmentally safe. As environmental laws heighten, especially those that prohibit pollutant discharge into rivers and lakes, precast concrete is additionally beneficial because it is made from natural materials. Precast concrete products are buried throughout the world as part of the stormwater management systems of nearly every modern city but do not themselves contribute to poor water quality.

Precast concrete is the choice material for products used in stormwater management systems. Precast structures are modular, can fit any design situation, are produced in a quality-controlled environment and are ready to install immediately upon arrival at the job site. Precast stormwater management components are easily produced to be watertight, durable during storage and transportation, easy to install, less vulnerable than competing products to damage during backfill, and are environmentally safe during operation.

## SUSTAINABLE BENEFITS



### SUSTAINABLE BENEFITS OF PRECAST CONCRETE

#### Recycling

Precast plants reuse formwork, in itself a conservationist act, and in doing so reduce construction waste that would otherwise be generated at a job site. In addition, cementitious materials used in concrete often contains manufacturing byproducts such as fly ash and blast furnace slag that would otherwise find their way to a landfill. Wastewater can be recycled for use in manufacturing. Steel used for concrete reinforcement is typically composed of 95 percent post-consumer recycled content.

#### Reduced Site Impact

Since precast concrete stormwater management products are manufactured off site and delivered on demand, there is a significant reduction in truck traffic, dust, noise and debris from formwork associated with poured-in-place products. Because precast concrete stormwater management components are modular and standardized, they can be delivered just-in-time and installed quickly, resulting in reduced construction times, less energy usage, noise and emissions from on-site equipment, all of which substantially reduces site impact.

#### Natural Materials

The cement used in concrete is made of natural materials such as limestone and clay. While the cement manufacturing process does produce carbon emissions, many cement companies are working to reduce their carbon footprints. Cement is generally a local material, with most cement plants relying on nearby limestone quarries. Aggregates used in the manufacturing of precast concrete

stormwater management products are generally extracted and manufactured regionally.

#### Durability

Concrete is a very strong and durable material, which is a significant sustainable attribute. It will not rust, rot or burn and has a service life of in excess of 100 years.

#### Precast Concrete and LEED

Precast concrete stormwater management products are a smart choice for projects applying for LEED certification. Most of the credits shown also have additional Innovation in Design points that are tied to exemplary performance of the credit listed.

#### LEED for New Construction and Major Renovation: A Scorecard

##### Site Development: Protect or Restore Habitat

*(Sustainable Sites Credit 5.1)*

Because precast concrete stormwater management products are cast in a plant and delivered to the site they can be installed with very minimal disturbance to the site.

##### Stormwater Design: Quantity Control

*(Sustainable Sites Credit 6.1)*

Most stormwater management plans will require components in the design to properly handle the stormwater runoff. Precast concrete stormwater products are clearly the superior choice.

##### Stormwater Design: Quality Control

*(Sustainable Sites Credit 6.2)*

Most stormwater management plans will require components in the design to properly handle the stormwater runoff. Precast concrete stormwater management structures are the superior choice.

# INSTALLATION

## **Construction Waste Management: Divert 50% (75%) From Disposal**

*(Materials and Resources Credit 2.1 and 2.2)*

Because precast concrete stormwater management products are cast in a plant and delivered to the site, there is little or no onsite waste management to consider during construction.

## **Recycled Content: 10% (20%) Post-Consumer Plus One-Half Pre-Consumer**

*(Materials and Resources Credit 4.1 and 4.2)*

Precast Concrete stormwater management products may contain supplementary cementitious materials such as fly ash and blast furnace slag that will add to the project's recycled content goals.

## **Regional Materials: 10% (20%) Extracted, Processed and Manufactured Regionally**

*(Materials and Resources Credit 5.1 and 5.2)*

The vast majority of materials that go into the construction of precast concrete stormwater management products are within a 500 mile radius of the precast plant.

## **LEED for Neighborhood Development Pilot Scorecard**

### **Green Infrastructure and Buildings: Minimize Site Disturbance in Design and Construction**

*(GIB Credit 6)*

Precast concrete stormwater management products installed with a small footprint can utilize existing utilities and minimize site disturbance.

### **Green Infrastructure and Buildings: Stormwater Management**

*(GIB Credit 7)*

Precast concrete stormwater management products are an economical choice to retain/treat stormwater underground, which keeps the ground above in a developable state.

### **Green Infrastructure & Buildings: Stormwater Management**

*(GIB Credit 14)*

Precast concrete pipe may contain supplementary cementitious materials such as fly ash and blast furnace slag that will add to the project's recycled content goals.

## **INSTALLATION PROCEDURES**

Proper installation of stormwater management systems is critical for maintaining structural integrity and watertightness. The installation site must be accessible to trucks weighing up to 80,000 pounds. The construction area should be free of trees, branches, overhead wires or parts of buildings that could interfere with the delivery and installation of the stormwater management system.



### **Lifting Apparatus**

Use approved lifting slings that will adequately handle the weight of the units. A spreader bar is also preferred. When lifting stormwater management devices, make sure chain or cable lengths are long enough to prevent contact with tongue and groove area and are kept at appropriate lifting angles. Use wooden blocks between sling and stormwater management wall if necessary. All lifting devices should meet OSHA requirements documented in the *Code of Federal Regulations* Title 29, Part 1926, or other applicable ASTM standards.

### **Recommended Bedding**

Use a minimum of 4 inches of approved bedding material compacted to 90 percent proctor in an area not less than the base area but preferably 6 inches beyond the outside of the structure's base. The area under incoming and outgoing pipes should be treated the same to prevent shearing of pipes. Local ground conditions may require additional bedding thickness, according to the engineer's recommendations. Setting the Base: Set the base on a graded bedding according to job specifications making sure boots or pipe openings match design elevations. Level the top of the base in both directions.

### **Pipe Connections and Inverts**

*(Based on manufacturer's recommendations)*

**Flexible Boot Connections:** Clean the pipe surface and the inside of the boot. Insert the spring line of the pipe flush with the inside of structure's wall or as allowed by jurisdiction, keeping the pipe centered in connector. Install all take-up clamps in grooves if provided at the receiving end of the connector. Tighten the clamp to recommended torque, which will vary depending on size and manufacturer's specifications.



Any grouting that will inhibit the design/flexibility of the connector should be avoided.

**Compression Type Connector:** Cut  $\frac{3}{4}$ -inch bevel on the end of the pipe to be inserted into the stormwater structure. Clean the pipe surface and inside area of connector. Lubricate the inside of the connector and the exterior area of pipe being inserted. Center the beveled end of the pipe into the connector. Keeping the pipe level, push the pipe into connector until pipe is flush with inside of the wall (or as required by local specifications).

**Mortar Joint:** Locate the pipe into the opening to meet elevations. Use non-stick mortar to completely fill voids around pipe. Allow proper curing time before backfilling.

**Pipe Stubs:** Any pipe stubs installed in the stormwater management structure must be restrained from movement to prevent blowout resulting from groundwater or any testing. A minimum length of 5 feet may be required.

### Joint Installation

**Butyl Gasket** – Use only manufacturer-recommended sizes for specific diameters. Clean and inspect tongue and groove surfaces. Surfaces should be free of all dust and debris.

**Confined O-Ring** – Clean and inspect joint surfaces. Lubricate the joint surface liberally. Lubricate O-Ring gasket thoroughly before placing into confined groove space provided. Run a smooth round object between the gasket and the tongue several times around the entire circumference. Lower the lubricated end of the next section making sure steps are aligned into final position. Keep sections level/plumb to prevent rolling the gasket or breaking the bell.

**Offset and Prelubricated Gaskets** – Install according to manufacturer's specifications.

### Precast Lift Hole Sealing (*full penetration*)

Lifting holes should be sealed by inserting a rubber plug or other approved material into the hole (if supplied) and/or filling with non-shrink mortar from the inside and the outside.

### Backfill Procedure

If you are vacuum testing, do the test before backfilling. Detecting leaks at this time is easy and repairs are simple. Backfill equally around the structure to prevent tipping. Compact fill-in lifts the same as with a standard trench procedure. Backfill material should be clean and free of large rocks (greater than 3 inches in diameter) and placed in uniform lifts less than 24 inches thick.

## CERTIFIED EXCELLENCE

From start to finish, the NPCA Plant Certification program sets the highest standards for plant facilities, production operations and quality control procedures. NPCA certified plants are dedicated to manufacturing first-class products. To maintain their NPCA credentials, plants must pass periodic, on-site certification inspections.

The NPCA Plant Certification program enables quality-conscious agencies, architects, engineers and users to identify and select high-quality precast concrete manufacturers

At no cost to specifiers, NPCA certification prequalifies manufacturers as companies capable of superior workmanship. You save money because you do not need to spend valuable time and resources inspecting a plant to ensure that its products will meet or exceed your expectations. You also save time when you work with certified precast plants because products arrive on the job site ready for installation. Material and labor costs are kept in check because quality control starts before the work order reaches the precast plant.

## INDUSTRY STANDARDS

### The Certification Process

To become an NPCA certified plant, a precast concrete production facility must exceed a level of excellence defined by NPCA in accordance with relevant industry standards. Plant inspections are performed by an engineer from an independent nationally accredited firm, and all certification applicants are graded on all critical aspects of plant operation. A standard grading schedule is used for all inspections to ensure uniformity. Inspections are performed during actual plant operation.

### The NPCA Certified Plant

Precast concrete plant operators committed to excellence seek NPCA certification, investing the time and resources required to meet the high standards demanded by the construction industry. Staffed by experienced personnel, plants complying with NPCA guidelines practice quality assurance at every step of the production process.

Plant certification guidelines require procedures and products to be inspected during each phase of manufacturing to ensure compliance with rigid industry requirements. As a result, products from NPCA certified plants are characterized by high quality, uniformity and consistency.

Each NPCA certified plant is also required to maintain an active plant safety program that meets or exceeds local, state, provincial and federal laws, including Occupational Safety and Health Administration (OSHA) and Canadian Centre for Occupational Health and Safety requirements.

## NPCA CAN HELP YOU FIND A STORMWATER PRODUCT MANUFACTURER IN YOUR AREA

Whether you need a custom design or a standard product, visit [www.precast.org](http://www.precast.org) or call (800) 366-7731 to find stormwater product manufacturers in your area.

At the NPCA Web site, you can select a zip code radius or state a specific location near your project. NPCA is a proven leader in the development of manufacturing and quality standards for precast products, including the publishing of technical manuals and underwriting of research. The NPCA Technical Services department staff also actively participates in standard-setting organizations such as ASTM and ACI.

NPCA can provide the data and support that you need to incorporate the latest precast concrete products into your design. Services include a Knowledge Base that includes information regarding specific design issues, and an online Community Forum, where questions are posted and issues discussed.

If you have questions about stormwater management products, please contact NPCA Technical Services either by e-mailing [technical@precast.org](mailto:technical@precast.org) or calling (800) 366-7731.

## ASTM INDUSTRY STANDARDS

**ASTM A185 / A185M** – “Standard Specification for Steel Welded Wire Reinforcement, Plain, for Concrete”

**ASTM A496** – “Specification for Steel Wire, Deformed, for Concrete Reinforcement”

**ASTM A497 / A497M** – “Standard Specification for Steel Welded Wire Reinforcement, Deformed, for Concrete”

**ASTM A536** – “Standard Specification for Ductile Iron Castings”

**ASTM A615 / A615M** – “Standard Specification for Deformed and Plain Carbon-Steel Bars for Concrete Reinforcement”

**ASTM A884** – “Specification for Epoxy-Coated Steel Wire and Welded Wire Reinforcement”

**ASTM C443** – “Standard Specification for Joints for Concrete Pipe and Manholes, Using Rubber Gaskets”

**ASTM C478** – “Standard Specification for Precast Reinforced Concrete Manhole Sections”

**ASTM C890** – “Practice for Minimum Structural Design Loading for Monolithic or Sectional Precast Concrete Water and Wastewater Structures”

**ASTM C913** – “Specification for Precast Concrete Water and Wastewater Structures”

**ASTM C923** – “Standard Specification for Resilient Connectors Between Reinforced Concrete Manhole Structures, Pipes, and Laterals”

**ASTM C990** – “Standard Specification for Joints for Concrete Pipe, Manholes, and Precast Box Sections Using Preformed Flexible Joint Sealants”

**ASTM C1478** – “Standard Specification for Storm Drain Resilient Connectors Between Reinforced Concrete Storm Sewer Structures, Pipes and Laterals”

## CASE STUDY

# EPA Gets Tough on Stormwater - Solution is Precast

The EPA is getting tough on stormwater erosion and contaminants. Here's a look at how precast concrete can successfully meet their requirements.

*(Reprinted from Precast Solutions magazine, published by the National Precast Concrete Association)*

Stormwater treatment used to be just a matter of channeling excess water safely into a lake or river. And channeling the water "safely" only meant making sure the water volume didn't damage life or property on its way to the destination. Once it reached the lake or river, it was someone else's concern. New EPA guidelines have changed all that.

When stormwater runs over a hard, non-porous surface like a parking lot or a street, it washes oil, silt and trash from the surface. Unless the stormwater is filtered, these pollutants may enter the water supply. In the past, this was not as big a problem as it is today, because most stormwater was filtered by running into and through several feet of soil. However, an increase in paved surfaces has created the need for man-made filtration of stormwater.

New EPA guidelines require larger cities and counties to take steps to improve stormwater quality prior to discharge. These steps include public education about stormwater runoff, street sweeping programs to remove trash, regulation of construction sites to minimize erosion, and the production of a "stormwater atlas" that details all components of a stormwater collection and discharge system. The target result is an 85 percent reduction in contaminants that would have otherwise entered the water system.

Here is a look at one stormwater treatment project that used precast concrete components to solve design and installation challenges. Both projects adapted antiquated stormwater treatment methods to meet modern standards.

### **Precast is the First Choice in Largo, Fla.**

The stormwater runoff from a 90-acre basin in Largo, Fla., was a major concern to the city's Stormwater Program, especially since the site also contained a 25-acre apartment complex. The previous system used in the basin merely drained the water, along with runoff containing hydrocarbons and trash, into the 8th Street discharge point. Since Largo is part of the EPA's NPDES (National Pollution Discharge Elimination System) Phase 1 program, requiring the city to take proactive measures to improve water quality, the basin was a natural target for a retrofit.

Mike Sepessy, stormwater program manager for the City of Largo, says he faced several challenges in this project. "First, since this was a municipal project, we were operating under a very tight budget. Using precast components helped to greatly reduce our cost," he says.

"Second, we needed a system that would incorporate two input pipes and a diversion box," he continues. "Since precast



components could be custom-designed for our needs, this was not a problem." Finally, since there was such a large drainage basin and lots of upstream flow, he needed to use a large stormwater separator system. "Again, custom-designed precast components provided our solution."

Sepessy adds that the lower cost and increased flexibility of precast concrete components compared to other types of construction helped to solve problems with other above- and below-ground water. "Since the water table here in Florida is only inches below the ground surface, and because excess water on the surface is a constant problem, we needed to use well-pointing equipment and mud pumps. Because we used precast concrete pipes, boxes and walls, we were able to add this other equipment in a cost-effective manner."

Chris Landt of CDS Technologies, the developer of the project, says, "Since the weir box we needed for the 8th Street Outfall project was so large (10 feet by 8 feet by 8 feet), it helped that the precaster shipped it to us in two pieces with a horizontal seam." He says this made installation of the box a lot simpler.

"For stormwater treatment systems, it's just a given that precast is the first choice," adds Landt. "It lasts longer than anything else and it's very strong." In fact, precast concrete can be designed to provide various strengths, depending on the need, and its strength gradually increases over time.

### **Project Profile**

**Project Name:** 8th St. Outfall

**Owner:** City of Largo, Fla.

**General Contractor:** Site Engineering Inc., Atlanta

**System Developer:** CDS Technologies, Canton, Ga.

**Precast Manufacturer:** Atlantic Precast, Sarasota, Fla.\*

*\*Atlantic Precast, Florida Division is a certified plant under NPCA's Quality Assurance/Plant Certification program.*

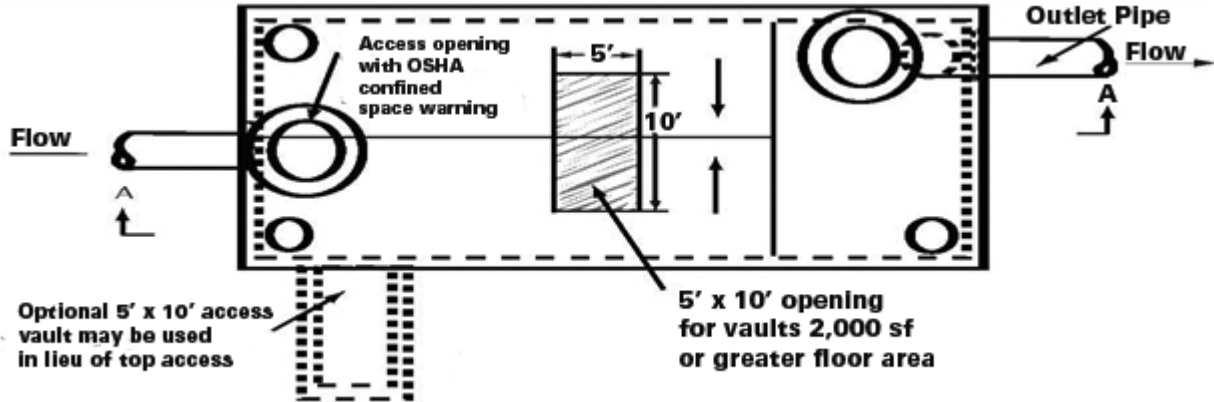

## Retention/Detention Systems

Underground stormwater retention/detention systems capture and store runoff in large pipes or subsurface structures. Stormwater may enter the system through a riser pipe connected to a catch basin or other stormwater collection structures, and then it flows into a series of underground chambers or components for storage. This captured runoff typically is retained throughout the stormwater event and then released directly into the surface waters through the outlet pipe. This outlet is sized to release the stored runoff at predetermined flow rates that serve to reduce the effects of pollutants leaving a site during peak flows. These systems typically are constructed in newly developed areas where land costs and availability are major concerns. They will generally be located under parking lots or other paved surfaces in commercial, industrial or residential areas.

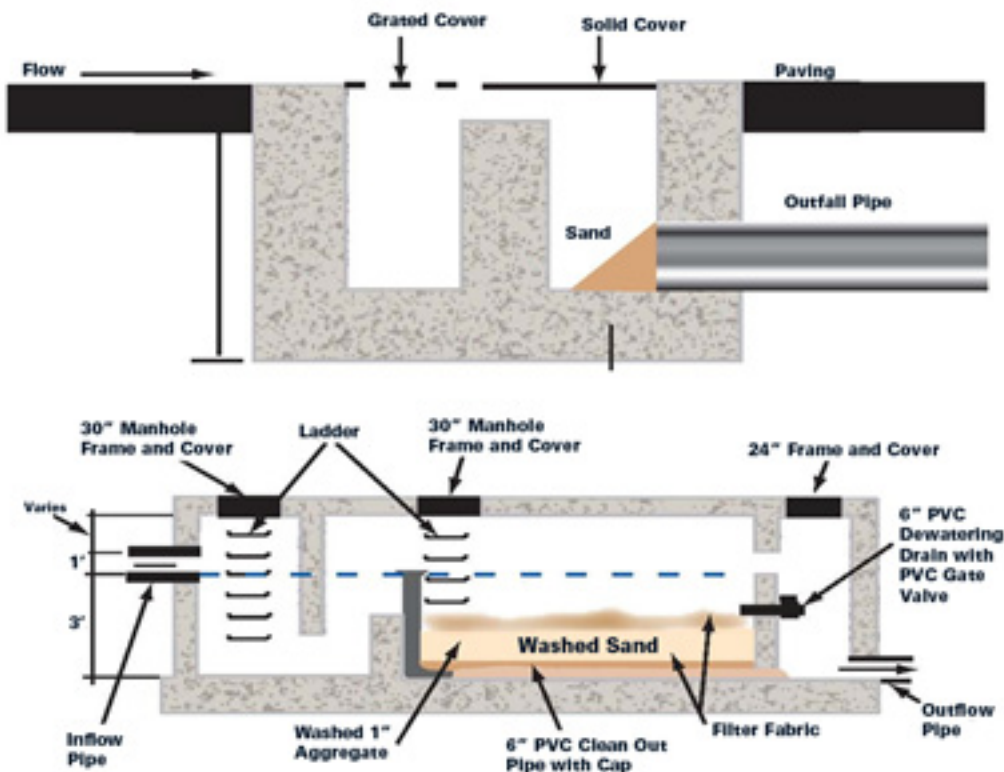



## Hydrodynamic Separator

Hydrodynamic separators are flow-through stormwater treatment structures with a settling or separation unit to remove sediments and other pollutants. No outside power source is required, because the energy of flowing water allows the sediments to efficiently separate. Depending on the type of unit, this separation may occur by means of swirl action or indirect filtration. There are many different technologies available and all are housed within a structure of some type. Due to their small size, they are especially well-suited in applications where land availability is an issue.

## Flow-through Stormwater Treatment Structures

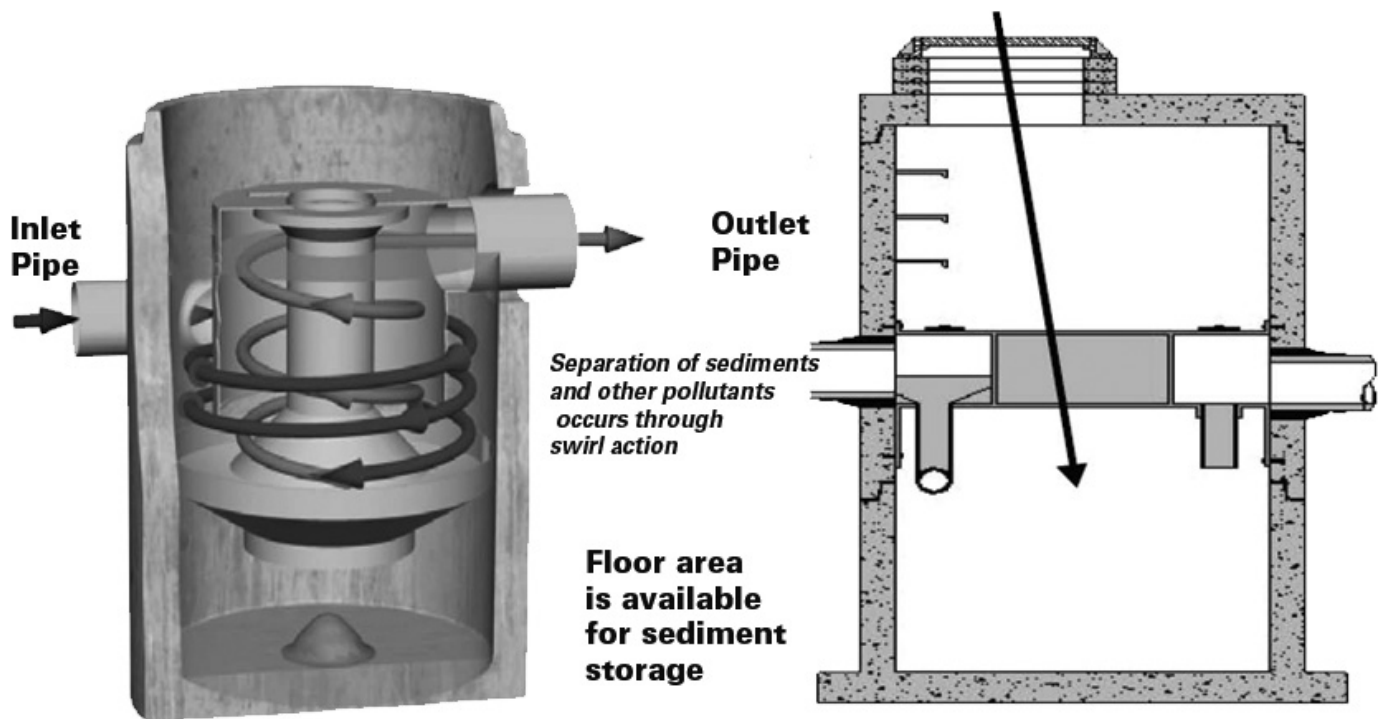

## STORMWATER ILLUSTRATED

### Wet Vault

Wet vaults and tanks are on-line underground facilities used for storing surface water. A wet vault has a temporary and a permanent water pool and may also have a constructed outlet that causes a temporary rise of the water level during a storm. Wet vaults and tanks are typically concrete structures designed to provide runoff treatment through the use of a permanent pool of water.

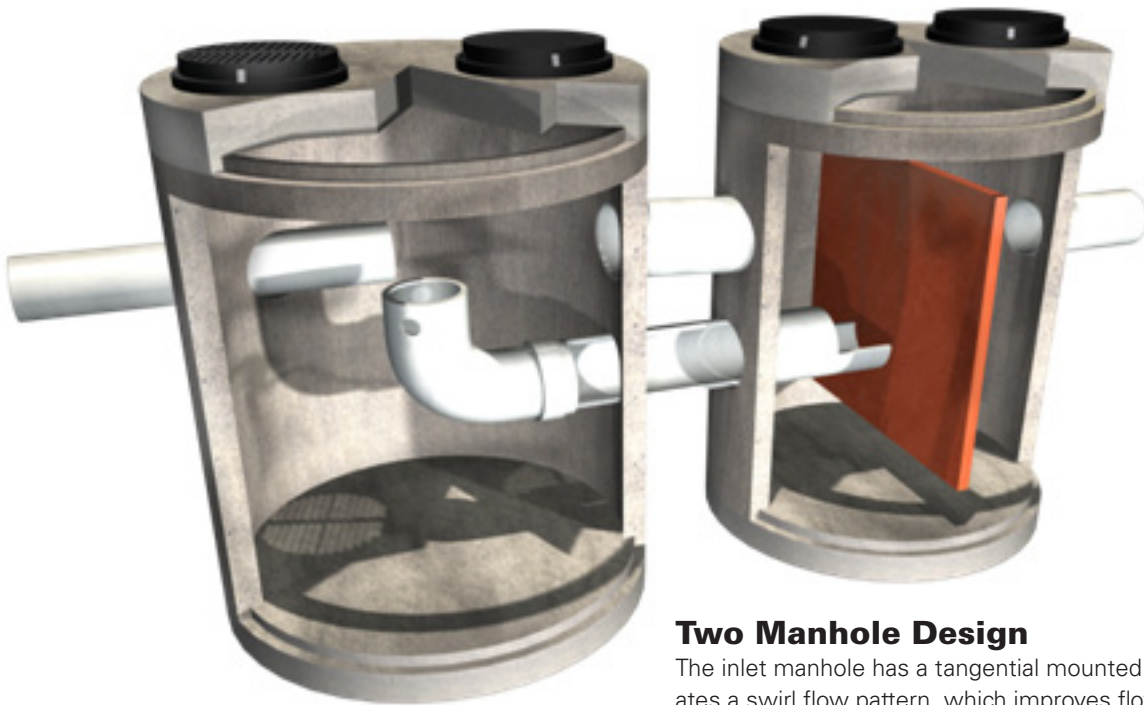
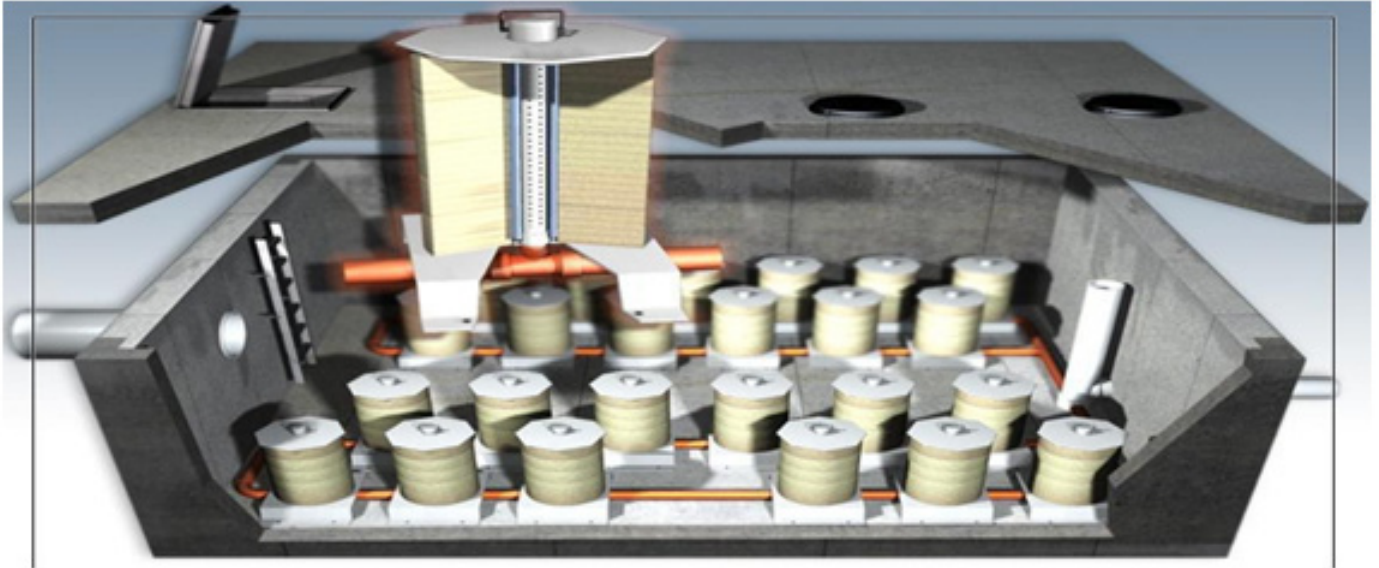

### Two Manhole Design

The inlet manhole has a tangential mounted inlet pipe that creates a swirl flow pattern, which improves flow distribution and reduces turbulence, thus enhancing sedimentation settling. Proper sizing essentially offers a complete removal of sandy sediment. The elbow pipe configuration in this particular design conveys flow to the outlet manhole where floating debris is retained by using an underflow baffle.

# STORMWATER ILLUSTRATED

## Drain Inserts

Drain inserts are manufactured filtration products placed in a drop inlet or catch basin inlet to remove sediment and debris. A multitude of inserts exist in various shapes and configurations.

Typically the insert consists of a frame that acts as the support structure for the filtering media and sediment/debris collection device. This frame generally rests beneath the grate of a drop inlet or is attached to the wall of a curb opening-style catch basin. Typically, a collection device made of polypropylene filter fabric or stainless steel will be attached to the frame, fitting entirely within the dimensions of the inlet structure without blocking the outlet piping.

Filtration media will be secured within the collection device and will vary by manufacturer. Media types include polypropylene, porous polymer, treated cellulose and activated carbon depending upon the targeted products.

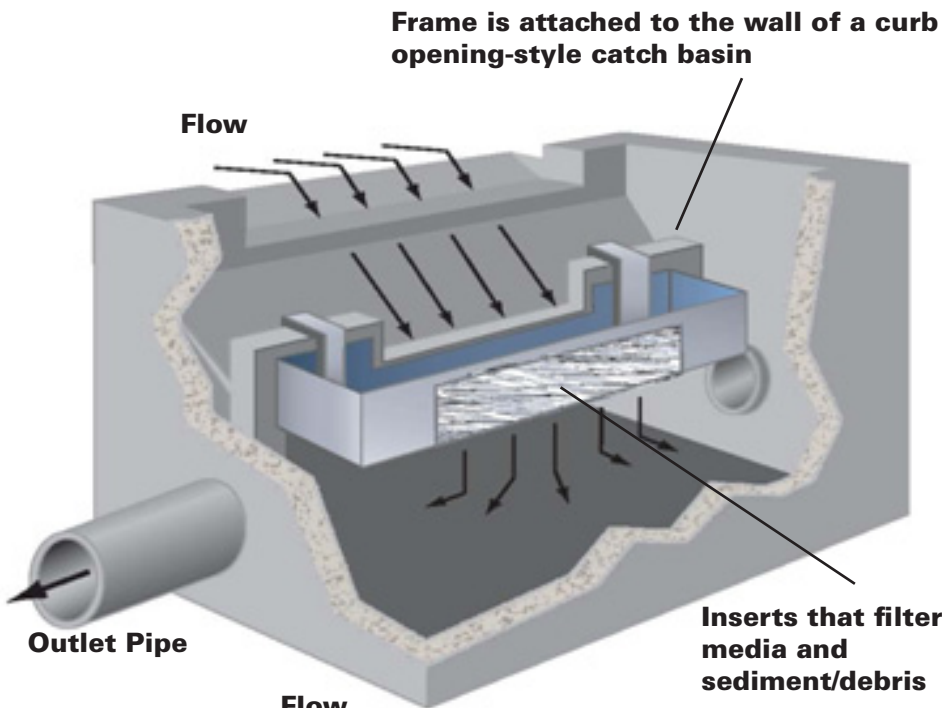

**Insert that filters media and sediment/debris**

**Frame rests beneath the grate of a drop inlet**

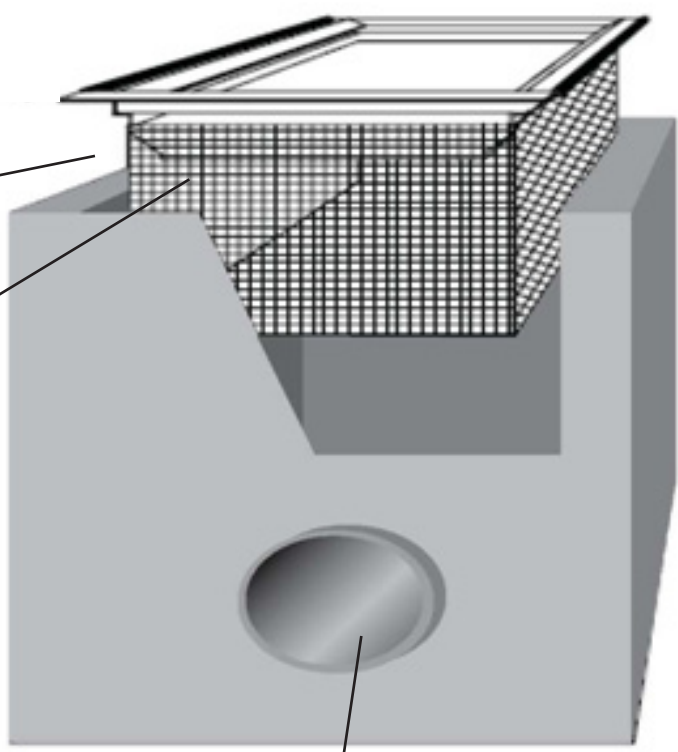
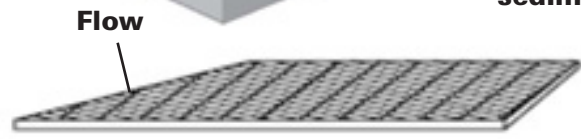

**Outlet Pipe**

### **Vault or Manhole**

This stormwater management structure uses a multifunction insert that traps solids greater than a certain  $\mu\text{m}$  in size, floating debris and hydrocarbons, and acts as a flow diffuser/distributor, helping to meet the EPA goals of gross pollution removal.

The structure improves scouring of the inlet side screen surface, thereby minimizing potential obstruction and maintenance. The entire floor area is available for sediment storage and is easily accessible for inspection and cleaning.

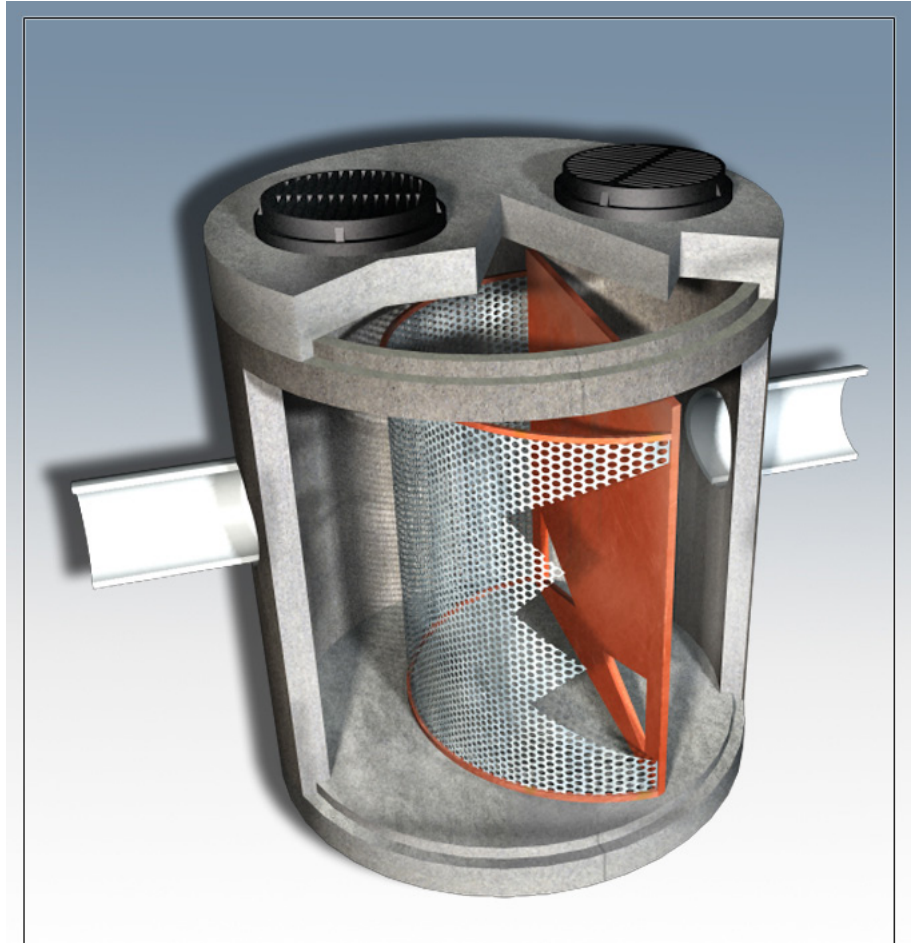

### **ACKNOWLEDGEMENTS**

Published by the Stormwater Management Product Committee of the National Precast Concrete Association. Thanks to:

Copyright 2011 by the National Precast Concrete Association

